

# The Self-Levelling Trolley

## Tracked Leveller 5.5 (With Crane Attachment)

The Tracked Leveller 5.5 with crane is one of the first tracked levellers to feature a crane attachment to lift and place loads onto the bed of the machine for transportation. The crane attachment benefits from a lifting capacity of up to 990kg, a slewing angle of 105° and a reach of 2m to 4.3m, depending on the weight of the load.

The Tracked Leveller 5.5 includes an automatic self-levelling deck and has a maximum capacity of up to 5.5t. It features bi-levelling technology, for ultimate manoeuvrability and control when traveling over rough and uneven terrain and even slopes.

This machine is perfect for lifting and placing materials such as steel and timber for transportation across busy construction sites and more.

### Reference Codes

**TPS 5.5 CRANE**



Able to pick up from the ground, lift loads onto its own bed, track to the final location and install items over rough terrain makes the Tracked Leveller 5.5 with crane one of the most versatile machines on any work site.

The automatic dynamic levelling means transporting goods over rough terrain is no problem for the Tracked Leveller 5.5 with crane.

### Features of the Tracked Leveller 5.5



Simple on-board power switch controls and easy access charger makes using and recharging simple.



Forklift and lifting points are included to move the Tracked Leveller 5.5 on transport or to harder to reach areas.



The deck can be moved between three heights for extra ground clearance.



The Bi-Energy option of the Tracked Leveller 5.5 means you can easily switch between diesel or electric power.

The Tracked Leveller 5.5 with crane can automatically dynamic level and lift 990kg, down to 300kg at 4.3m outreach.



# Key Features With A Crane

Tracked Leveller

## Key Features

- Bed capacity: 5500kg
- Crane capacity: 990kg
- Maximum/minimum width: 1.8m / 1.42m
- Maximum crane lifting height: 6.9m
- Automatic dynamic self-levelling
- Maximum gradeability: 25°
- Radio remote with digital feedback
- Maximum speed: 3.7km/h
- Weight: 2990kg
- Bi-Energy power (diesel and electric)

## Multi-Functional Radio Remote Control

The radio remote control with digital feedback allows the operator to single handedly drive, lift and install materials while receiving real-time information from the high resolution colour display.



## Technical Specifications

<b>Max capacity (bed)</b>	5500kg
<b>Max capacity (crane)</b>	990kg
<b>Min height</b>	2.61m
<b>Max lifting height (crane)</b>	6.9m
<b>Min width</b>	1.42m
<b>Max width</b>	1.8m
<b>Power (diesel engine)</b>	Yanmar 3TNV76 (diesel) - 25HP
<b>Power (electric engine)</b>	48V - 3kW
<b>Battery pack</b>	Lead Crystal n°8 180Ah 48V
<b>Battery charger</b>	110v / 32A
<b>Recharging time</b>	5h
<b>Longitudinal levelling (front)</b>	20°
<b>Longitudinal levelling (rear)</b>	15°
<b>Lateral levelling</b>	+/- 15°
<b>Max speed</b>	max 3.7km/h
<b>Max gradeability</b>	25° (with self-levelling on)
<b>Side slope</b>	25°
<b>Length</b>	3.0m
<b>Total weight</b>	2990kg

The maximum lifting height is 6.9m and max outreach is 4.3m.

The Bi-Electric power of the Tracked Leveller 5.5 allows operators the option of running with diesel or electric power.

The bed of the Tracked Leveller has a maximum capacity of 5.5t.



Dynamic levelling and the ability to increase or decrease the ground clearance makes this a truly adaptable machine.



# Trolleys

## Technical Data - Dimensions (mm)

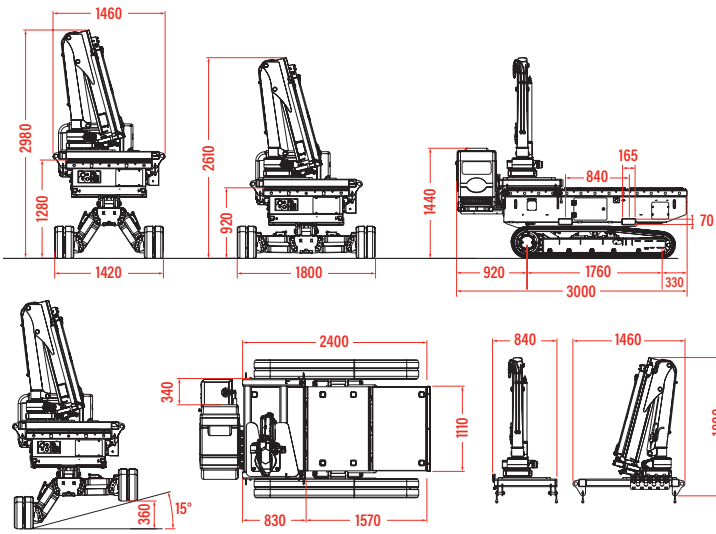

## Technical Data - Gradeability (mm)

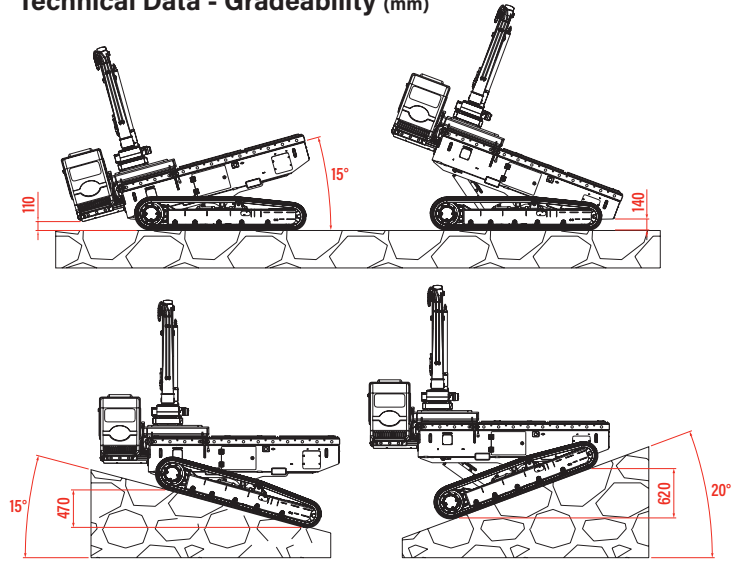

## Rated Loads - Front Loading

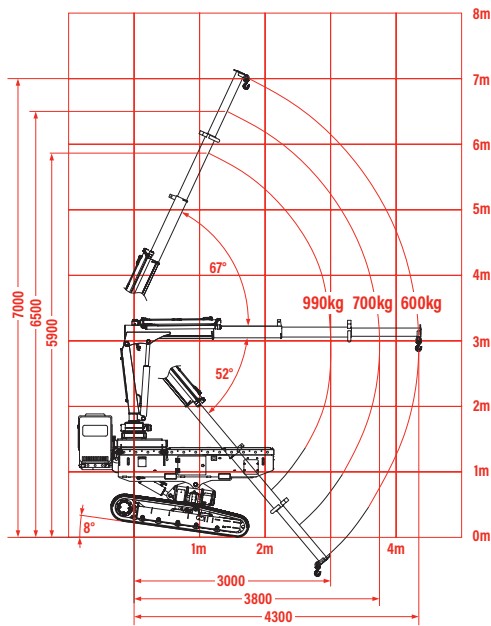

## Rated Loads - Side Loading

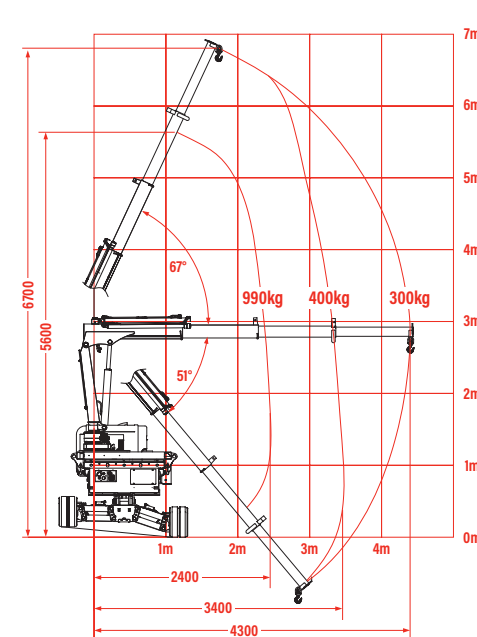

## Rated Loads - Top Down

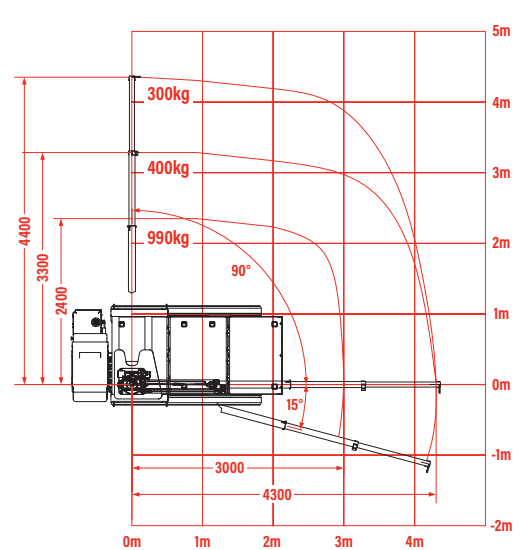

Durable tracks enable the Tracked Leveller to traverse rough uneven terrain and also smooth ground with ease.



The hook is rated to hold 2t of weight which means the max capacity of 900kg has a more than 2:1 safety ratio.



The lifting points on both the bed and crane platform means the crane can easily be removed to use the Leveller as a trolley only.

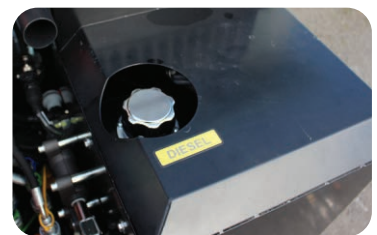

The Bi-Electric power choice on the Tracked Leveller 5.5t makes working in confined areas and external worksites possible.