

# Trolleys

## A Unique New Self-Level

### Multi-Loader 3.0 BL [3000kg]

The battery-operated Multi-Loader 3.0 BL is the perfect tool for moving goods up to 3000 kg over difficult terrain.

The Multi-Loader 3.0 BL uses a special Bi-Levelling technology for optimal control and manoeuvrability when working in confined spaces and on busy construction sites. Even while moving over inclines and uneven terrain, its automated self-levelling load-deck guarantees maximum control in the safe delivery of cargo.

This environmentally friendly carrier has a 48v rechargeable battery and works both indoors and out. It can also move across horizontal slopes of up to 25° and vertical slopes of up to 25°.

The ML 3.0 BL Tracked Leveller has a class-leading electric drive with two 5.3kW extremely quiet IP67-rated AC electric motors, and it has three power management modes with varying speeds. It can be configured with AGM or lithium batteries.

Glass, machinery, lumber and other commodities can all be transported on site with the help of the Multi-Loader 3.0 BL. Plus with the optional non-marking tracks the fully electric ML 3.0 BL is perfectly suited for working in places such as shopping centres, rail stations and other locations with sensitive environments.

#### Reference Codes

AGM Battery Code: **TPS 3.0 ABL**

LTH Battery Code: **TPS 3.0 LBL**



#### Technical Specifications

	ELC	LTH
<b>Capacity</b>	3000kg	
<b>Min width</b>	1460mm	
<b>Max width</b>	1640mm	
<b>Min height</b>	740mm	
<b>Length</b>	2400mm	
<b>Longitudinal levelling front</b>	20°	
<b>Longitudinal levelling rear</b>	15°	
<b>Lateral levelling</b>	+/- 14°	
<b>Gradeability</b>	25°	
<b>Side slope</b>	25°	
<b>Max speed</b>	4.2km/h	
<b>Electric motor power</b>	2 x 5.3kW	
<b>Voltage</b>	48V	
<b>Battery charger</b>	No² 65-48V (110/220v)	
<b>Battery pack</b>	Lead Crystal No <sup>6</sup> 180Ah 48V	210Ah - 48V
<b>Recharging time</b>	3.5hr - 65A	3.5hr - 65A
<b>IP protection</b>	IP67	
<b>Weight</b>	1855kg	1670kg

#### Power Mode Load Examples

Power Mode	Load			Max Speed
	0kg	1500kg	3000kg	
<b>ECO</b>	~4500m	~3800m	~3200m	1.2km/h
<b>STD</b>	~4200m	~3400m	~2700m	1.8km/h
<b>POW</b>	~3900m	~3000m	~2200m	4.2km/h



The Multi-Loader 3.0 BL features an optional tow bar accessory.



#### Optional Maxi-Chassis With Ramps

**Chassis:** 2450mm (l) x 1300mm (w)  
**Ramps:** 2500mm (l) x 360mm (w)



The Multi-Loader 3.0 BL optional ramp kit allows the easy loading of wheeled or tracked equipment.

**Example Of Usage**

The Multi-Loader 3.0 BL approaches the load to be lifted from underneath with its low profile height of 740mm.



Once in place, the Multi-Loader 3.0 BL can raise up which at the same time narrows the width from 1640mm to 1460mm.

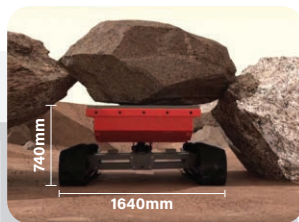

The Multi-Loader 3.0 BL can raise and lower from 740mm to a maximum height of 1070mm.

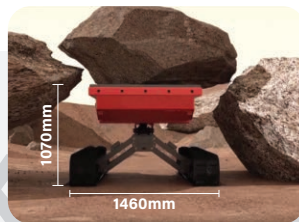

Then it can be driven away and using its dynamic auto-levelling can traverse gradients of up to 20°, keeping the load flat & stable.



The Multi-Loader 3.0 BL can operate with a maximum speed of 4.2km/h

**Key Features**

- Capacity: 3000kg
- Maximum/minimum width: 1640mm / 1460mm
- Automatic dynamic self-levelling
- Three driving modes: Main / ED-S / DC-S
- Three power management modes: ECO / STD / PWR
- Automatic tilt alarm with speed reduction
- Auxiliary hydraulic sockets
- Maximum gradeability: 25°
- Controlled by radio remote
- Only 3.5 hours to fully charge
- Maximum speed: 4.2km/h
- Weight: 1855kg (AGM) / 1670kg (LTH)

The Multi-Loader 3.0 BL features automatic dynamic self-levelling technology to ensure the stability of the load.



The Multi-Loader 3.0 BL can work on slopes up to 20° all while keeping the load level.

The Multi-Loader 3.0 BL is fully controlled by radio remote.

**Technical Data (mm)**

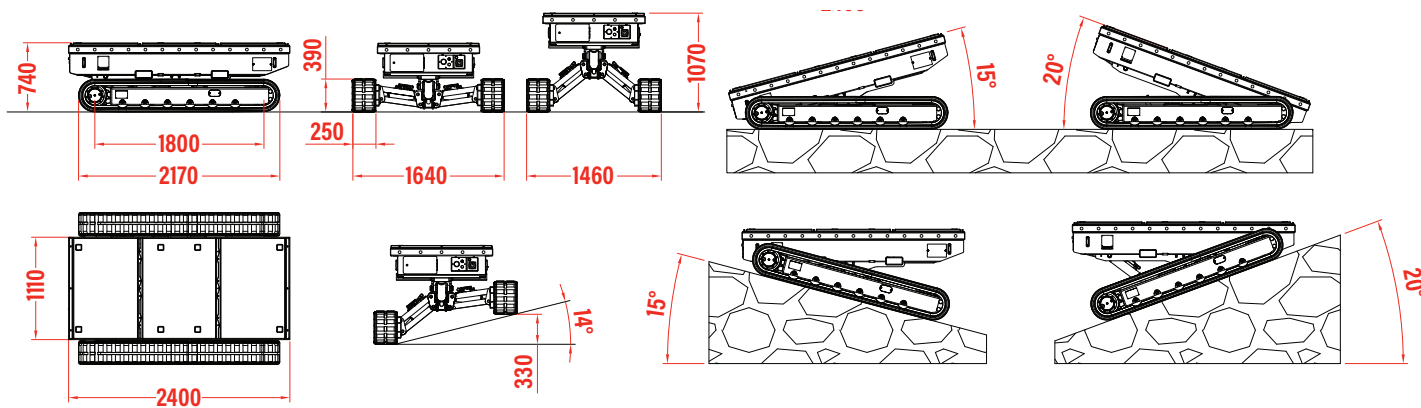

ALL DATA/MEASUREMENTS/DESCRIPTIONS IN THIS SPECIFICATION SHEET IS NON-BINDING. GGR GROUP RESERVES THE RIGHT TO CHANGE THE SPECIFICATIONS WITHOUT PRIOR NOTICE. PLEASE CHECK WITH A MEMBER OF GGR GROUP'S TECHNICAL TEAM FOR SPECIFIC ENQUIRIES AND THE LATEST INFORMATION.

Multi-Loader 3.0 BL